



# MONTERO

PRETENSADOS Y EXCAVACIONES, S.L.  
37497 GALLEGOS DE ARGANÁN (SALAMANCA)  
Fijo 923 47 72 30 Móvil 689 76 23 99  
Fabrica 923 47 72 55 Fax 923 47 70 90  
**WWW.MONTERO-SL.COM**



## Arqueta 30

Pesos:

Tapa con Marco	30 kg
Arqueta sin Fondo	37 kg
Arqueta con Fondo	43 kg
Arqueta Sifónica	50 kg

fabricamos  
arquetas inclinadas y  
arquetas con paso eléctrico

Tambien hay  
tapa rejilla  
de hormigón

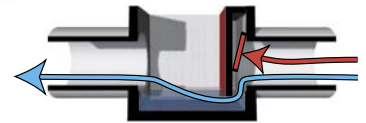
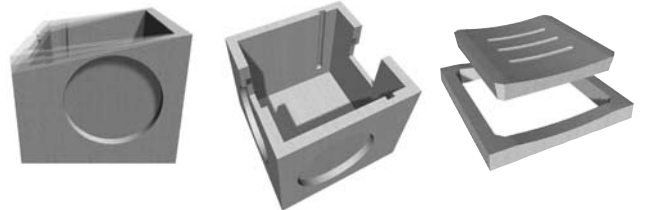

Se puede suministrar con sifón

Cotas:

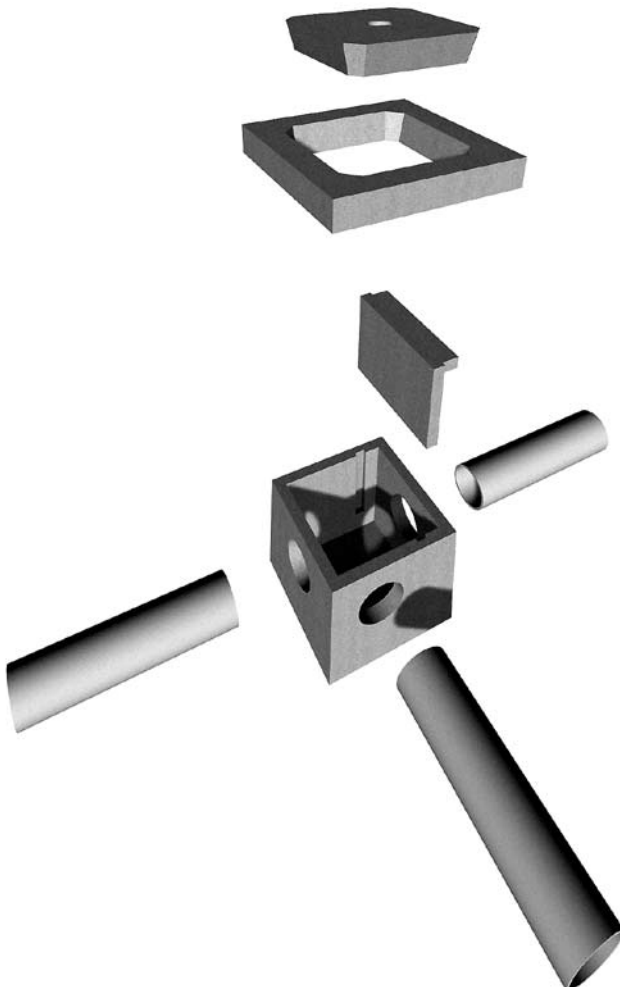
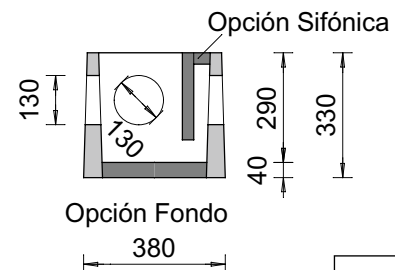
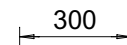
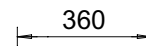
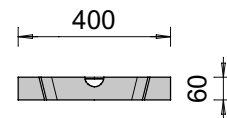

Escala 1/20  
Cotas en mm

